



by Schutte & Koerting

---

## 2-1/2" TURBODRAFT – OPERATING INSTRUCTIONS

---

### SET UP

1. Submerge TurboDraft in 2' to 3' of water.
2. Stretch lines (1 1/2" + 2 1/2"), remove any sharp turns or kinks.
3. Connect to pump panel – 1 1/2" to a 1 1/2" discharge connection, 2 1/2" to pump piston intake or butterfly valve. This connection must have a variable gate valve and an air bleeder is required.
4. At this point TurboDraft is ready to be put into service.
5. Open tank to pump valve.
6. Increase engine pressure to 150 psi.
7. Open 1 1/2" discharge completely and maintain 175 psi.
8. Open air bleeder on piston intake or butterfly valve.
9. When water discharges from bleeder, close bleeder and slowly open intake valve approximately 1/2 way.
10. Close tank to pump valve.
11. Water supply is established.
12. Open tank fill valve 1/4 - 1/3 open and refill tank (always keep tank full).
13. When tank is full, close tank fill valve.
14. You are ready to use the supply source provided by TurboDraft.

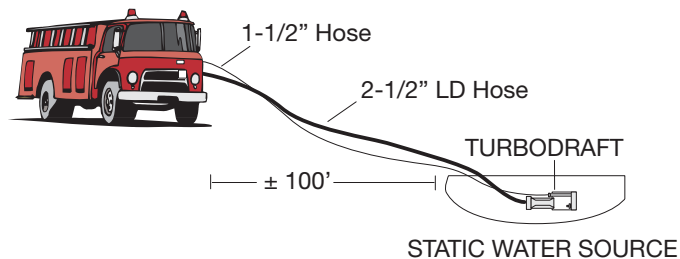

### USE

1. Available water (see chart).
2. Open appropriate discharges to flow water.
3. Do not over exceed the supply source availability.
4. Maximum flow is achieved when the supply line starts to slightly collapse.
5. If the supply line collapses simply decrease discharge flow and the supply line will recharge itself.
6. Always maintain discharge engine/pump pressure manually or with pressure governor supplying the TurboDraft.

### STRAINER CLEARING

1. Open tank to pump valve.
2. Close intake.
3. Maintain pressure.
4. Run with intake closed for approximately 15-30 seconds using tank water.
5. Slowly re-open intake valve, re-establishing supply.
6. Close tank to pump.
7. Open tank fill 1/4 - 1/3. Refill tank.
8. When tank is full, close tank fill valve.
9. Resume flow operations.

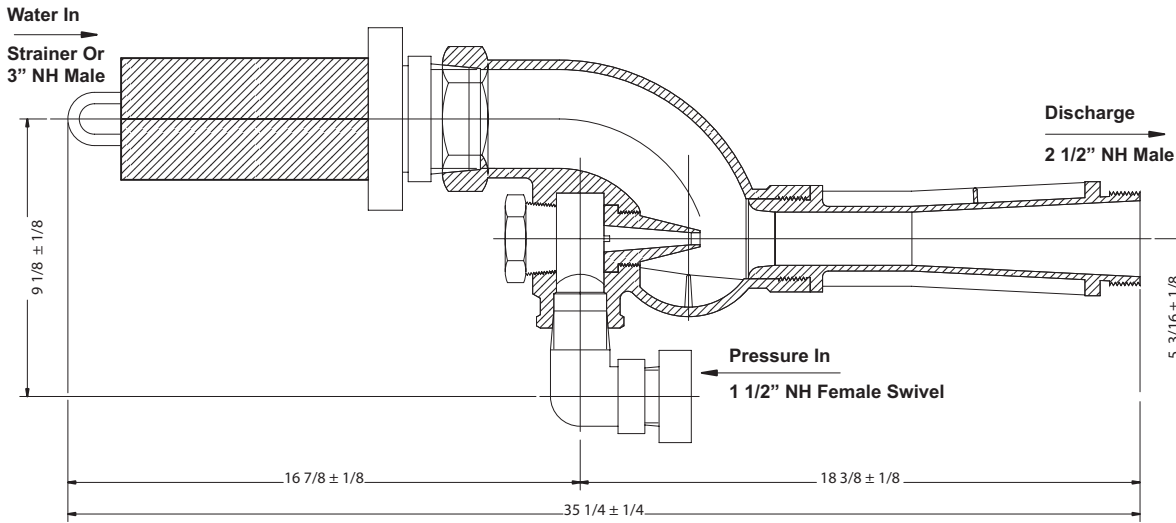

**TurboDraft Operation**

Once the TurboDraft Fire Eductor has been set up it can be quickly placed into service. The steamer suction valve is left closed and its air bleeder is opened. The 1.5" line is charged to approximately 175 psig. The force of the flow combined with TurboDraft eductor technology creates a suction which draws water from the standing water supply. As this happens, the return line is charged back to the fire truck. Once the air is bled from the supply line, the bleeder is closed and the steamer valve is opened. At this point the water supply has been established. 60 GPM is re-circulated through the truck to maintain a continuous flow and 264 GPM is available to supply tanker trucks or fill portable tanks. Useable fire flow will vary based on elevation and hose friction loss. (See table below.)



**Tap Water Sources in Remote Locations**

Rural fire companies need creative solutions to utilize water sources that are not accessible using typical drafting techniques. Schutte & Koerting's TurboDraft Fire Eductor allows fire companies to tap into water supplies like ponds, streams, and swimming pools up to 250' away and can generate flows up to 264 GPM.

2 1/2" TurboDraft Fire Eductor Performance

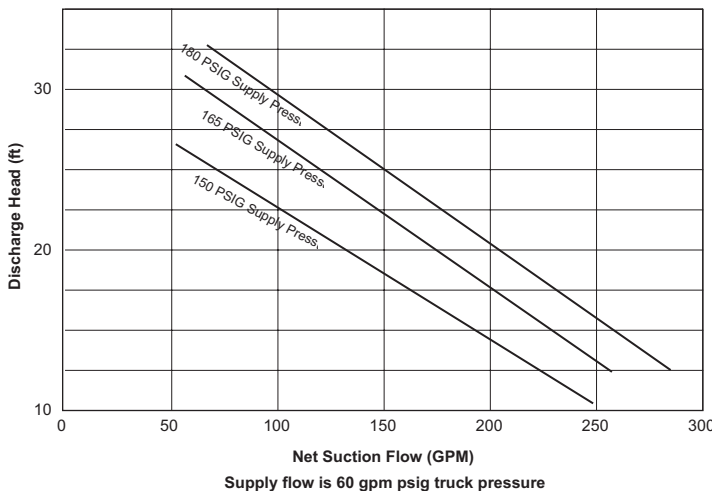

Overall Length: 30"  
Weight: 20 lbs.  
Connections: 1 1/2" NST Female Inlet  
2 1/2" NST Male Outlet

Distant Water Source Situation			
Length of 2-1/2" Hose	Lift	Pump Discharge Pressure	Max. Avail. Fire Flow
50'	10'	175 psig	264 GPM
	20'	175 psig	185 GPM
100'	10'	180 psig	224 GPM
	20'	180 psig	157 GPM
150'	10'	185 psig	189 GPM
	20'	185 psig	128 GPM
200'	10'	190 psig	173 GPM
	20'	190 psig	110 GPM

010606

